



FA732/A2 Network & Borehole Pressure Transmitters Selection Guides

| | |
|---|--------|
| Network Pressure Transmitter Selection Chart..... | Page 2 |
| Borehole and Level Transmitter Selection Chart..... | Page 3 |

Ashridge Engineering Ltd
Unit 1a, 58 North Road Industrial Estate
Okehampton, Devon, EX20 1BQ, UK

Tel: +44 (0) 1837 53381
Fax: +44 (0) 1837 55022
E-mail: sales@ash-eng.co.uk
Website: www.ash-eng.co.uk

FA732/A2 Network & Borehole Pressure Transmitters

User Guide

Network Pressure Transmitter

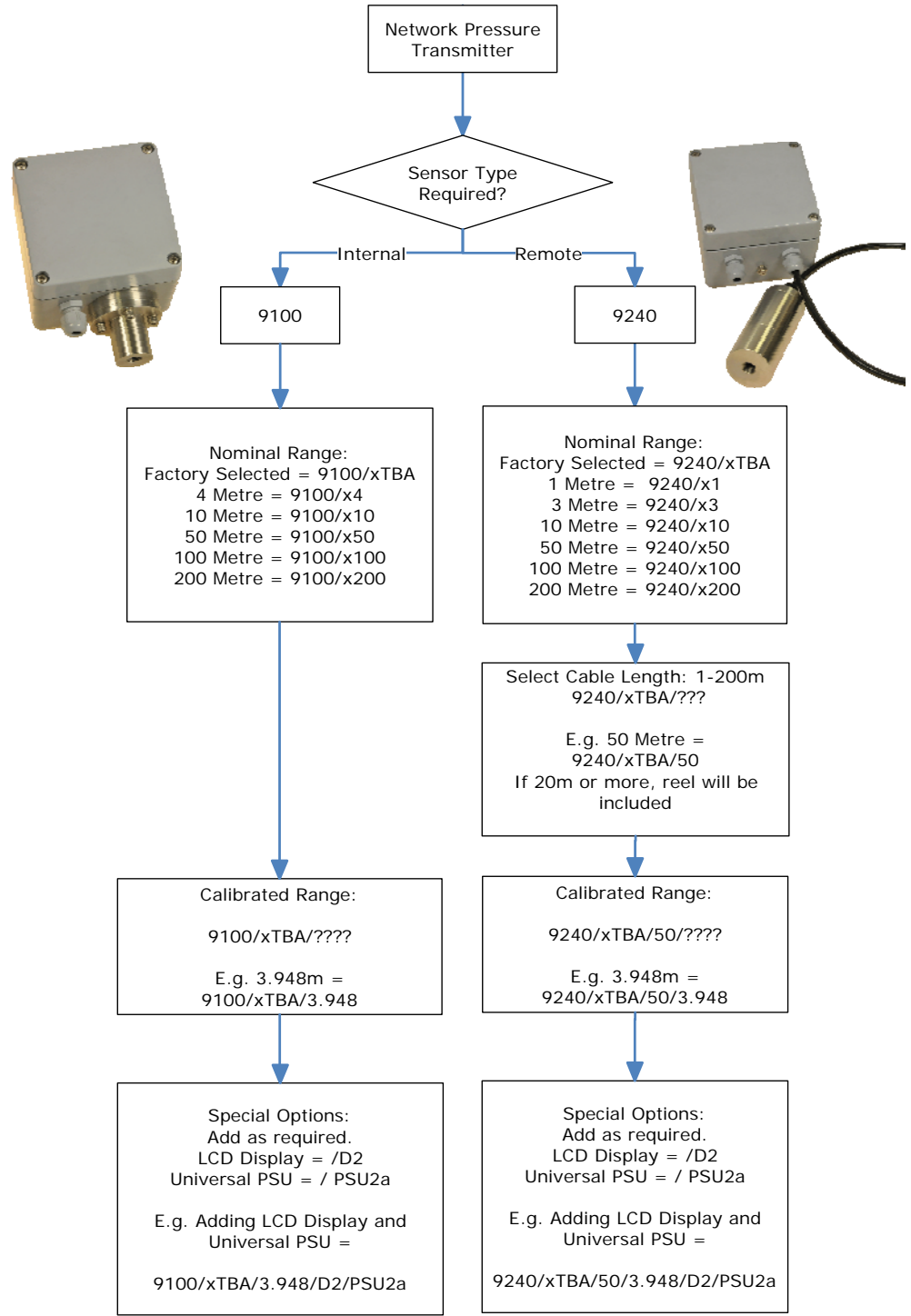

9100 D2 Display Option

FA732/A2 Network & Borehole Pressure Transmitters

User Guide

Borehole & Level Transmitters

Ashridge Engineering Limited
 Unit 1a, 58 North Road Industrial Estate
 Okehampton, Devon, EX20 1BQ, UK
 Tel: +44 (0) 1837 53381, Fax: +44 (0) 1837 55022
 sales@ash-eng.co.uk www.ash-eng.co.uk

