

# Ashridge 852 Dual Display Transformer Temperature Monitor

## Model 852 - 216



## Installation and Operation Manual

Version 1.5a March 2010

### Contents

1	WELCOME .....	2
2	PRODUCT SUPPORT .....	2
3	INSTRUMENT DESCRIPTION AND CAPABILITIES .....	2
4	SPECIAL FEATURES .....	4
5	INSTALLATION .....	6
6	SETTING UP THE 852 .....	9
7	MODBUS NETWORKING .....	21
8	DAILY OPERATION .....	27
9	APPLICATION NOTES .....	28
10	APPENDICES.....	35
11	RECORD SHEET .....	40

## 1 Welcome

This manual has been completely rewritten and is structured to take the user through the installation and commissioning of the instrument stage by stage. It provides useful application information to the System Designer and practical step by step guidance for the Commissioning Engineer and the End User.

## 2 Product Support

Ashridge Engineering Limited  
Unit1a, 58 North Road Industrial Estate  
OKEHAMPTON  
EX20 1BQ  
UK  
Telephone: +44 (0) 1837 53381  
Fax: +44 (0) 1837 55022  
Email: sales@ash-eng.co.uk

Support is normally available during our office hours 09:00 to 17:00 Monday to Friday.

## 3 Instrument Description and Capabilities

### 3.1 General Description

- 3.1.1 The Ashridge 852 Transformer Temperature Monitor is an intelligent instrument that monitors winding temperature and flexibly controls transformer cooling fans and pumps. Temperature sensing is achieved by using PT100 (Platinum Resistance) probes with "Hot Spot" oil temperature correction to IEC 354 applied by measuring the current in the transformer circuit via a Current Transformer. Two displays are used, the first is a 5 digit 7 segment display and is used to indicate the Hot Spot oil temperature, the second, 3 digit 7 segment display is used to indicate the Top Oil temperature.
- 3.1.2 The hottest winding temperature is always displayed; when another winding is selected the unit will revert to the hottest winding after 1 minute. The hottest winding is defined as the winding, which is more than 2.5 degrees higher than any other winding. The Top Oil temperature is always displayed on the 3 digit LED display. **Please note:** Due to the different algorithms used for the Hot Spot and Top Oil temperatures, it is possible that with no winding input the displays may differ by 1 degree, this is normal.

- 3.1.3 The operating temperature range of the Monitor using a three-wire PT100 probe is from 0°C to 200°C. The Current Transformer input(s) has an operating range of 0 to 10 Amps AC with 100% overload capability.
- 3.1.4 Inputs to force pump and fan operation from a remote point are provided. Additional inputs provide a feedback system to confirm that pump and fan operation demands are met and allows the 852 to raise an alarm if the cooling plant demand is not met.
- 3.1.5 Dedicated function clean contact relay outputs are available to:
- i) Operate fans
  - ii) Operate pumps
  - iii) Indicate an over temperature alarm
  - iv) Output an over temperature trip
  - v) Indicate a fan or pump failure
  - vi) Indicate an internal failure, power failure or a PT100 input fault
  - vii) Relay 6 has been provided as user selectable
- Fan, Pump, Alarm, Trip, & relay 6 temperature thresholds are user programmable. Normally open or closed operation is strap selectable for each output.
- 3.1.6 Analogue output(s), which can be user programmed to a number of different operating ranges, facilitates connection to SCADA systems for remote temperature monitoring. Computer monitoring and networking of one or more instruments is available using a MODBUS RTU protocol network presented on an RS485 interface at the instrument
- 3.1.7 The 852 features a watchdog system which raises an alarm in the event of important external and internal failures.
- 3.1.8 The Unit is configurable using a built in keypad and display. Password protection is used to prevent unauthorised reconfiguration. Configuration data, once entered, is retained indefinitely. A real time clock is also provided which will keep running for up to two weeks following a power failure. No batteries are required in this equipment.
- 3.1.9 The equipment may be AC or DC powered over an operating range of **44 to 265 Volts AC/DC**.

### **3.2 Electromagnetic Compatibility & Low Voltage Directive Compliance**

- 3.2.1 The 852 Units are designed to operate in the electricity substation environment on systems operating up to 500kV. The 852 has been extensively tested to meet EMC and LVD requirements.

### **3.3 Isolation Information**

- 3.3.1 The 852 has three separate electrically isolated sections to ensure by design its suitability for use in the immediate vicinity of high voltage equipment.

These sections are all isolated from each other to a proof voltage of 2000 Volts AC RMS. The isolation is valid between

- Input Section (PT100 & CT Input Ports) & Power Supply Input
- CT to CT(s)
- Input Section and Output Section (Relays, Analogue & MODBUS)
- Power Supply and Output section

In addition the relay contacts are further isolated from the Output Section circuitry with a withstand voltage of 2000 VDC

## 4 Special Features

### 4.1 Hot Spot Temperature Correction

4.4.1 The 852 corrects the temperature measured by the PT100 probe in accordance with the formula described in IEC354. This correction requires knowledge of the current flowing in the circuit connected to the transformer and three other parameters stored in the 852.

4.4.2 The IEC354 formula implemented in the 852 is

$$\theta \text{ Hot Spot} = \theta \text{ top-oil} + H g_r K^\gamma$$

Where H = Manufacturers factor usually due to the placement of PT100 sensor

Where  $g_r$  = Manufacturers Hot Spot gradient

Where K = CT input as Load factor

Where  $\gamma$  = A Transformer dependant factor

4.4.3 The 852 Plus maintains programmable values for ONAN, OFAN and OFAF gradient curves. When the cooling plant is started the hot spot correction moves from the ONAN to OFAF curves, for 2 gradient, or ONAN to OFAN, then OFAN to OFAF for 3 gradients, after user programmable transfer delays.

### 4.2 Step Mode (Oil Breakdown protection)

4.2.1 In some applications, particularly railway traction and CHP power stations a large step change in current through the transformer can cause the oil to breakdown, before the temperature rises sufficiently to switch on the cooling pump.

4.2.2 To support this type of application, the 852 has an operating mode which can be set to detect a given step change in current and run the pump for a pre-set period following that change. This feature is accessed through the on step, "on-st" parameter in the configuration menu.

### 4.3 Cooling Plant Failure Detection

- 4.3.1 A “Cool Fail” relay contact set is provided to indicate when fans or pumps have not responded to the demand signal from the 852 Plus. The “Cool Fail” relay is energised following a programmable delay of between two and thirty minutes after the issuing of a demand to which the cooling plant has not responded.
- 4.3.2 Two methods of detecting cooling plant failure are provided and described below. See Section 7 Page 18
- 4.3.2.1 Method one is to detect by contact closure the operation of the electrical contactor controlling the fan or pump. This method is simple to implement but does not prove conclusively that the plant is running. It only proves that the electricity supply to the contactor is present. The 852 monitors these contacts and where, following a cooling demand, they remain open for longer than the user programmed period, the “Cool Fail” contacts are closed.
- 4.3.3 Method two uses external CT’s and external burden resistors to independently monitor the running currents of the Fan and Pump motors. The 852 Plus monitors these currents and where they are outside the values set by the user for greater than the programmed period, the “Cool Fail” contacts are closed.
- 4.3.4 The action of the 852 is the same whatever input method is chosen.
- (i) Where a Fan has a ‘failed’ input the ‘Cool fail’ relay energises after the pre-set time period.
  - (ii) Where the Pump has a ‘failed’ input the ‘Cool fail’ relay is also energised after the pre-set time period,
  - (iii) Additionally, where the pump has failed the unit will not allow the ‘Hot spot’ correction to move from the ONAN to the OFAF curve. As soon as it detects the correct cooling plant status or running currents then the ‘Hot Spot’ correction will operate normally, via the transfer timer and the ‘Cool fail’ relay will de-energise.
- 4.3.5 It should be noted that the cool fail protection facility also operates as described above when either manual initiation (ct types only) or watchdog activation of the cooling plant occurs.

#### **4.4 Monitor Fault Detection & Failsafe Operation**

4.4.1 The 852 features a watchdog based internal monitoring system which closes dedicated alarm contacts in the event of any of the following:

- A Failure of the PT100 probe or its associated wiring
- A Power failure
- Detectable internal failures

4.4.2 In the event of a failure of the type listed above, in addition to the alarm, the pump and fan relays automatically energises to ensure that the plant is cooled to provide emergency overheat protection.

4.4.3 In addition to the alarm contact the analogue output No 1 is clamped to 0mA which is particular useful as a failure detection method in 4-20mA systems.

4.4.4 Finally the design of the 852 is such that in the event of a Watchdog alarm event, operation of the trip relay is inhibited.

#### **4.5 Flexible Functionality**

4.5.1 The 852 is a very flexible instrument and can be supplied with additional features or application specific subsets of standard features to best meet customer needs.

4.5.2 For example the instrument can be supplied without the cool fail facility or with an application tailored to meet the specific needs of a core temperature protection system requirement.

4.5.3 Please contact the Ashridge Okehampton office for these or any other special functional requirements.

### **5 Installation**

#### **5.1 Installation considerations**

5.1.1 The 852 should, wherever possible, be mounted inside the substation building and powered from the dc supply. Where it is not possible to mount the 852 within the substation building it should be mounted away from direct midday sunlight, as elevated temperatures will lower the expected life of the electronic components.

## 5.2 Mechanical Dimensions

5.2.1 The 852 is supplied in a standard wall mounting instrument case. Dimensions are shown below.

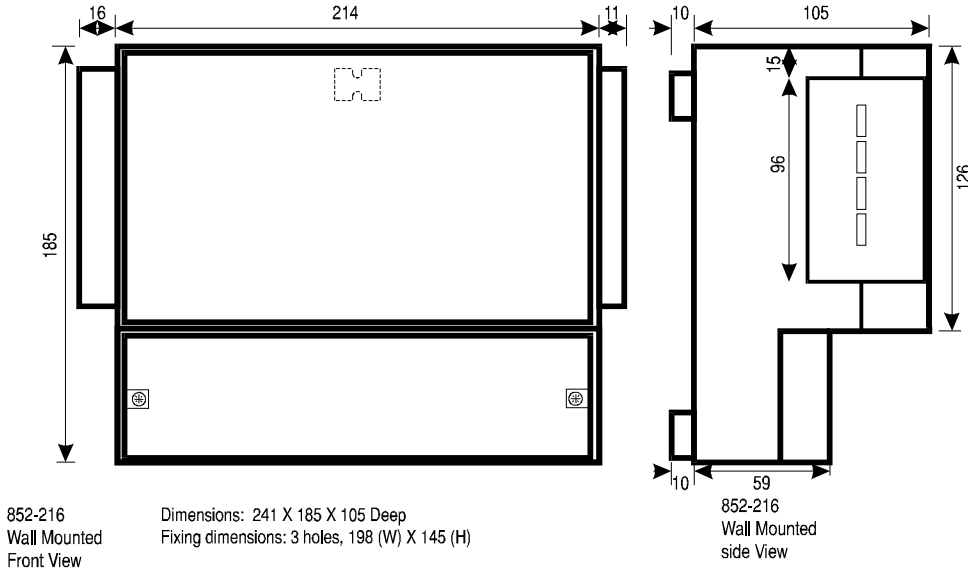

## 5.3 Electrical Installation Overview

5.3.2 Figure 5.3 shows the general electrical wiring arrangements for the 852 equipment. Installers should also consult the site owner's type approval or type registration records to see if any additional specific installation requirements are recorded.

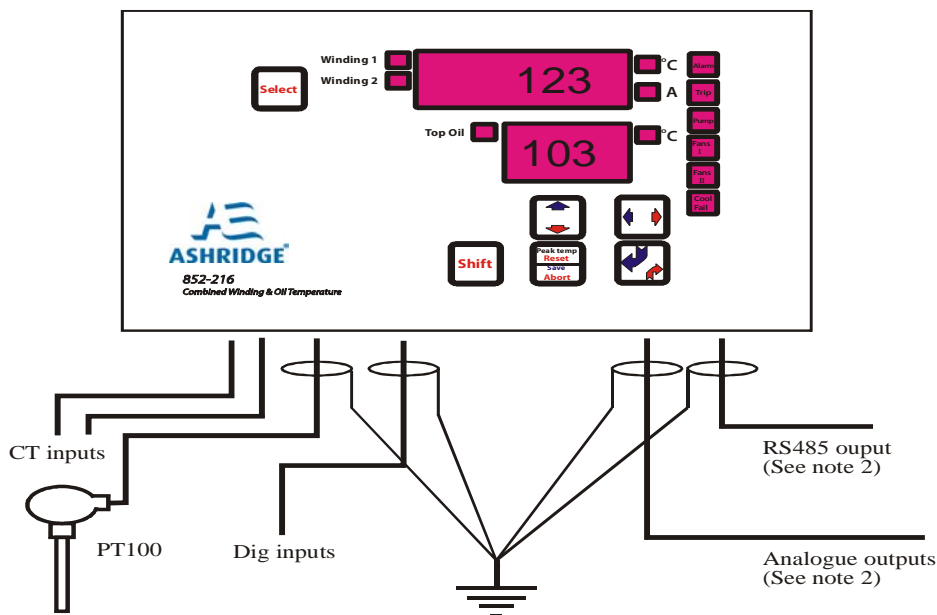

Note 1: All cables should be screened or S.W.A. (Steel Wire Armoured) with the screen connected to earth at one end only, preferably using a star earth system.

Note 2: Where fitted, the analogue and RS485 outputs may also require LTU (Line Termination Units) where they may be considered at risk of lightning strikes etc.

Figure 5.3 General Electrical Connection Details

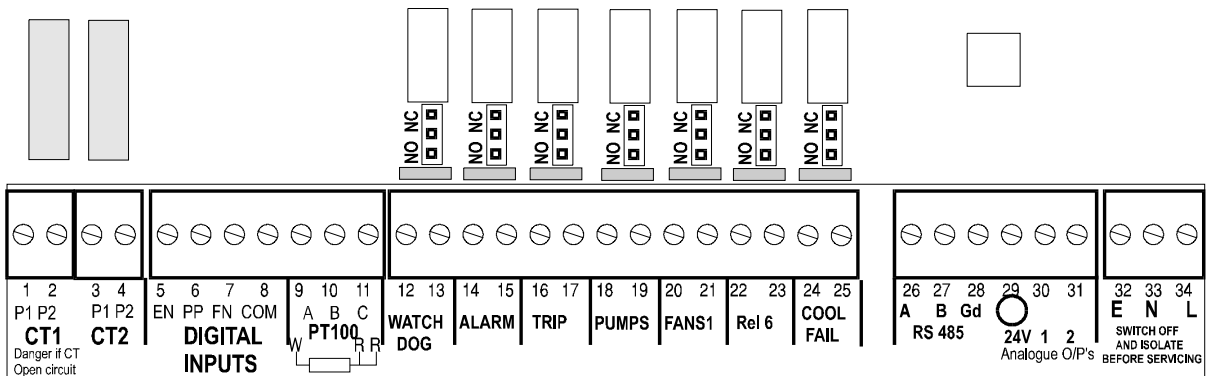

Figure 5.4

### 5.4 Connecting Terminal Arrangements (Wall Mount Version)

**Note:** For DC power supplies substitute L & N for + & - (polarity is unimportant), the 'E' has no electrical connection and has been added for terminal block stability.

#### IMPORTANT - TERMINAL BLOCKS

When tightening the terminal blocks it is imperative that the terminals are not over-tightened as a breakage may occur, this is especially important for the Power supply and CT inputs. Ashridge Engineering Ltd assumes no liability where individual terminal posts are broken.

5.4.1 Figure 5.4 above shows the connecting terminal arrangements for the Wall Mounted version of the 852. The function of most of the terminals is self evident, from the labelling but those for the digital inputs are tabulated below for clarity.

Label	Terminal Block No	Function
EN	5	Remote ON/OFF Control of Fans and Pumps
PP	6	PUMP Monitoring Input
FN	7	FAN Monitoring Input
COM	8	Common Terminal - Use as described below
W	9	White PT100 wire
R	10	Red PT100 wire
R	11	Red PT100 wire

Table 5.4.1

#### IMPORTANT - SAFETY PRECAUTIONS

Access to terminal blocks requires the removal of the equipment covers. It is imperative that all sources of power, including CT outputs are made safe and isolated from the 852Plus in accordance with relevant procedures before removal of the cover.

#### IMPORTANT – INTERNAL HARDWARE CONFIGURATION

Before making any changes to internal strapping ensure that the required links are identified and the new and old link positions noted before any changes are made.

## **5.5 Remote Control and Cool Fail Wiring and Configuration (Wall Mount)**

- 5.5.1 To provide Remote ON/OFF control of Fans and Pumps it is necessary to wire a clean contact between the EN and COM terminals. Closure of the contact will cause the pump and fan relay outputs to switch on after a short delay and remain on until the contact between EN and COM is opened again.
- 5.5.2 To provide the contact method of “cool fail” detection, wire a clean contact between the FN1 and COM for the Fans and the PP and COM for the Pump must be provided.
- 5.5.3 To provide contact method of “cool fail” detection wire the CT outputs and burden resistor must together produce a voltage range of 0V to 2.2VAC (Nominal running voltage = 1.5VAC) across the inputs.
- 5.5.4 For external burden resistor operation, the resistor may be valued and rated as appropriate in conjunction with the CT output range, but again must not produce a voltage range outside the 0V to 2.2VAC (Nominal running voltage = 1.5VAC).
- 5.5.5 Where the standard model of 852 is used and the cool fail facility is not required, select ‘none’ in the configuration menu.







## **5.6 Relay Strap Setting (Wall Mount Version)**

- 5.6.1 Each of the six relays can be set up to present open or closed contacts for the condition. The strap positions for each setting option are shown at the top right and middle right hand side of Figure 5.4 above.
- 5.6.2 The watchdog relay is normally energised, that is when power supply, PT100 input, and internal self-check are all healthy. All other relays are normally de-energised and energise only at the programmed operating points.

## **6 Setting Up the 852**

### **6.1 Control Button Functions**

- 6.1.1 There are five buttons on the front panel of the 852. The functions performed by each of these buttons are tabulated below.
- 6.1.2 Each button, except SHIFT has multiple functions. There are two modes of operation in the 852, which are called NORMAL & PROGRAMMING. Use of the SHIFT button provides two functions for each of the other four buttons in each of the operating modes.

Button	Name	Mode	Function
	SELECT	Normal	Used to select Winding temperature, note: after 1 minute the display returns to the hottest winding
	SHIFT	N/A	Used to change function of a key from the BLUE symbol to the RED symbol when in programming mode.
	ENTER	Normal	No function
		ENTER + SHIFT	Used to enter programming mode when pressed for two seconds
		Programming	Used to step forward through a programming loop
		Programming with SHIFT	Used to step backwards through a programming loop
	UP	Normal Up + Shift	Used to display Pump & Fan running currents (when in CT feedback mode)
		Normal	No function
		Programming	Raises the value of the flashing digit
		Programming Up + Shift	Lowers the value of the flashing digit
	PEAK TEMP	Normal	Displays the Peak Temperature and the Date and Time of occurrence
		Normal Peak Temp + Shift	Resets the Peak Temperature value to zero
		Programming	Saves the newly entered values
		Peak Temp + Shift	Aborts the programming process
	LEFT	Normal	No function
		Left + Shift	Displays the 852 version number, serial number and type on release
		Programming	Moves the flashing digit to the Left
		Programming Left + Shift	Moves the flashing digit to the right

**6.2 General Notes on Programming**

- 6.2.1 Access to the various programmable parameters of the 852 is by numeric pass codes. These pass codes are fixed in the factory and cannot be changed. The pass code for each group of parameters is given in the appropriate section of this manual.
- 6.2.2 If an incorrect pass code is entered then programming is inhibited and the display dims. The user is then able to view, but not change, the relay settings by pressing the ENTER button to step on to the next parameter.
- 6.2.3 If programming mode is entered but at any stage there is no button press for approximately two minutes then the 852 automatically returns to normal operation.
- 6.2.4 Programming can be aborted at any stage by first pressing the SHIFT and then the ENTER buttons.

**6.3 Setting the Time and Date**

- 6.3.1 The 852 Real Time Clock operates to a 24 hour HH:MM format. The built in calendar is valid up to the year 2100. To set the date and time proceed step by step as in the table below.

Stage	Action & Response
1	Press and hold the SHIFT and ENTER buttons together until "rEAdy " is displayed. (The display will briefly show "Setup" )
2	Release the SHIFT and ENTER buttons and the display shows "br1te"
3	Press SHIFT and ENTER buttons again and the time will be displayed with the hours flashing.
4	To increase the hours press the UP button To decrease the hours press the SHIFT and UP buttons When hours are correct press ENTER and the minutes digits now flash
5	Increase or decrease minutes using the UP and SHIFT buttons as above and press ENTER when correct. The date is now displayed with the day number flashing
6	Increase or decrease the day number using the UP and SHIFT buttons as above and press ENTER when correct. The date is now displayed with the month number flashing. Increase or decrease the month number using the UP and SHIFT buttons as above and press ENTER when correct. The date is now displayed with the year number flashing.
7	Increase or decrease the year number using the UP and SHIFT buttons as above and press ENTER when correct. The word "br1te" is now displayed.
8	Press PEAK TEMP to save the new values and return to normal mode. Alternatively press SHIFT and PEAK TEMP to abort.

## 6.4 Adjusting the display brightness

6.4.1 The display brightness can be adjusted to one of fifteen levels. In some lighting conditions, it can be difficult to see the step changes at the brightest end of the adjustment range. These step changes become much more noticeable as the display is made dimmer.

6.4.2 To adjust the brightness level of the 852 display proceed as follows

Stage	Action & Response
1	Press and hold the SHIFT and ENTER buttons together until "rEAdy " is displayed. (The display will briefly show "Setup" )
2	Release the SHIFT and ENTER buttons and the display shows "br1te"
3	To increase the display brightness press the UP button To decrease the display brightness press the SHIFT and UP buttons
4	Press PEAK TEMP to save the new value and return to normal mode. Alternatively press SHIFT and PEAK TEMP to abort the changes

## 6.5 Adjusting the Relay Set Points

6.5.1 The 852-216 provides five user programmable relay contact outputs to:

- operate cooling fans
- operate cooling pumps
- 1 off user defined relay contacts
- provide an over-temperature alarm signal
- provide an over-temperature trip signal

The operating temperatures for the ON and OFF points of each of these outputs is user programmable. A delay in relay operation after the pre-set temperatures are reached is also programmable.

6.5.2 To start the relay set point programming it is necessary to know the pass code which is the five digit number 00042. Note that when entering a pass code the operation starts with the least significant digit and works toward the most significant digit. There is no need to enter leading zeros however.

6.5.3 When ready to programme relay set points proceed as shown in the two Tables 6.5.3A and 6.5.3B below. Table 6.5.3A shows step by step instructions to access and programme the first parameter in the Group.

Table 6.5.3B then summarises the displays and purpose of each parameter in the group. Note that the figures shown as displayed in these procedures are those for an ex-factory 852. Subsequent field programming will cause them to be different.

Stage	Action & Response
1	Press and hold the SHIFT and ENTER buttons together until "rEAdy " is displayed. (The display will briefly show "Setup" )
2	Release the SHIFT and ENTER buttons and the display shows "br1te"
3	Press the ENTER button and the pass code prompt "----0" will be displayed with the zero digit flashing. Use the UP button to increment the value of the flashing digit to " 2"". If you go beyond "2" the use SHIFT and UP buttons together to decrement it again.
4	When satisfied that the least significant digit is correct, press the TOP OIL button. The display will now change to this "----0-" with the zero again flashing. The digit "2" you have already programmed is now hidden, but it is remembered by the 852.
5	Use the UP button to set the value of the digit to " 4 " Again the SHIFT and UP buttons may be used to decrement the value if you overshoot.
6	Now press and hold the ENTER button. The upper display will show "ALArn" and the lower display will show "on". Now release the button and the display will show " on 90.0 " with the right hand " 0 " flashing
7	Using the UP and SHIFT buttons, increment or decrement the digit to the desired value. Note that the increment and decrement of a digit will overflow and underflow to the higher order digits.
8	Use LEFT to move on to the next digit. The LEFT and SHIFT buttons pressed together will return to the previous digit.
9	When satisfied press and hold the ENTER button to show the next parameter. The entire sequence may now be repeated for each relay setting value as shown in Table 6.5.3B below.

Table 6.5.3A

Display with ENTER Button Pressed	Display with ENTER Button Released	Remarks
AlArN	on 90.0	Alarm relay 'Switch On' point in C (rising temp)
AlArN	oF 85.0	Alarm relay 'Switch Off' point in C (falling temp)
Delay	5Ec 3	Alarm relay switching delay time in seconds
PuNP	on 750	Pump relay 'Switch On' point in C (rising temp)
PuNP	oF 55.0	Pump relay 'Switch Off' point in C (falling temp)
DelAy	5Ec 3	Pump relay switching delay time in seconds
Fans1	on 75.0	Fan relay 'Switch On' point in C (rising temp)
Fans1	oF 55.0	Fan relay 'Switch Off' point in C (falling temp)
DelAy	5Ec 3	Fan relay switching delay time in seconds
Tr1P	on120.0	Trip relay 'Switch On' point in C (rising temp)
Tr1P	oF115.0	Trip relay 'Switch Off' point in C (falling temp)
DelAy	5Ec 6	Trip relay switching delay time in seconds
Rel 6	On 75.0	Relay 6 'Switch On' point in C (rising temp)
Rel 6	OF 55.0	Relay 6 'Switch Off' point in C (falling temp)
DelAy	5Ec 3	Relay 6 switching delay time in seconds

Table 6.5.3B

- 6.5.4 There is, effectively no end to this sequence as the parameters will continue to scroll round on an endless loop until either aborted or saved. You can now:
- Press PEAK TEMP to save the changes. " sAUE " is displayed.
  - Press SHIFT and PEAK TEMP to abort the changes " Abort" is displayed.

## 6.6 Adjusting the operational parameters (Part I)

- 6.6.1 The operational parameters set up group comprises the entries for:
- The number of gradients required, etc
  - The four analogue outputs to the local metering or SCADA
- 6.6.2 The pass code for operational parameter setting is 00066. When ready to programme the operational parameters proceed as follows. Note that the figures shown in these procedures are those for an ex-factory 852. Subsequent field programming will cause them to be different.

Stage	Action & Response
1	Press and hold the SHIFT and ENTER buttons together until "rEAdy " is displayed. (The display will briefly show "Setup")
2	Release the SHIFT and ENTER buttons and the display shows "br1te"
3	Press the ENTER button and the pass code prompt "----0" will be displayed with the zero digit flashing. Use the CT button to increment the value of the flashing digit to " 6"". If you go beyond "2" the use SHIFT and UP buttons together to decrement it again.
4	When satisfied that the least significant digit is correct, press the LEFT button. The display will now change to this "----0-" with the zero again flashing. The digit 6" you have already programmed is now hidden, but it is remembered by the 852.
5	Use the UP button to set the value of the digit to " 6 " Again the SHIFT and UP buttons may be used to decrement the value if you overshoot.
6	Now press and hold the ENTER button. The display will show "Grad". Now release the button and the display will now show "1" flashing
7	Using the UP and SHIFT buttons, increment or decrement the digit to the desired value. Note this allows 1, 2 or 3 gradients to be selected (default value = 1).
8	When satisfied press and hold the ENTER button to show the next parameter. The entire sequence may now be repeated for each parameter setting value as shown in Table 6.6.2B below.

Table 6.6.2A

Display with ENTER Button Pressed	Display with ENTER Button Released	Remarks / Actions Required
Grad	1	Selects number of gradient (1, 2 or 3)
T-lag	N1n 8	Exponential timer to simulate thermal lag in transformer. Range 0 – 10 Minutes in 1 minute steps
On-sT	onan STep	Enables Step Mode operation of cooling pump
Thresh	A 2.500	This only appears if “ on-sT” is set to STEP This sets the CT current threshold for the step change (after the CT current has been higher than the threshold for more than 90 seconds range 1-240)
TIME	Min 90	Min 90 This only appears if “ on-sT” is set to STEP Time before the Pump returns to local control. Range 1 – 240 Minutes
RollaV	AV 2	Rolling average filter to reduce display flicker Range 0-10 seconds, with a default value of 2
Op1 n	4-20 0-10 0-20	Select output current range using the UP button Range 0-200
Range	0-200 0-150 30-150	Selects the temperature range using the UP button
Op2 n	4-20 0-10 0-20	Select output current range using the UP button
Op2 S	HS-2 T-oil CT	Selects if output 2 provides 2nd Winding (Hotspot 2), top oil temperature or the Current Transformer input value
Type	CoTact cT None	Select the type of cool fail input detection between contact or CT input
Delay	NIn 2	Time delay before cool fail message appears and cool fail relay activates. Range 2 – 30 Minutes

Table 6.6.2 B

**6.7 Adjusting the operational parameters (Part II)**

- 6.7.1 The operational parameters set up group comprises the entries for:
- The temperature correction characteristics, for each winding, in accordance with IEC 354
- 6.7.2 The pass codes for each winding parameter setting is: Winding 1 = 00067 & Winding 2 = 00068. Note: The number of gradients selected under password 66 will actively change these settings. When ready to programme the operational parameters proceed as follows. Note that the figures shown in these procedures are those for an ex-factory 852. Subsequent field programming will cause them to be different.

Stage	Action & Response
1	Press and hold the SHIFT and ENTER buttons together until "rEAdy " is displayed. (The display will briefly show "Setup" )
2	Release the SHIFT and ENTER buttons and the display shows "br1te"
3	Press the ENTER button and the pass code prompt "----0" will be displayed with the zero digit flashing. Use the CT button to increment the value of the flashing digit to "7". If you go beyond "7" use SHIFT and UP buttons together to decrement it again.
4	When satisfied that the least significant digit is correct, press the LEFT button. The display will now change to this "----0-" with the zero again flashing. The digit 6" you have already programmed is now hidden, but it is remembered by the 852.
5	Use the UP button to set the value of the digit to " 6 " Again the SHIFT and UP buttons may be used to decrement the value if you overshoot.
6	Now press and hold the ENTER button. The display will show "onAn". Now release the button and the display will now show "15.0" with the right hand " 0 " flashing
7	Using the UP and SHIFT buttons, increment or decrement the digit to the desired value. Note that the increment and decrement of a digit will overflow and underflow to the higher order digits.
8	Use LEFT to move on to the next digit. The LEFT and SHIFT buttons pressed together will return to the previous digit. Repeat stages 7 & 8 for the third (most significant) digit
9	When satisfied press and hold the ENTER button to show the next parameter. The entire sequence may now be repeated for each parameter setting value as shown in Table 6.6.2B below.

Table 6.6.2C

Display with ENTER Button Pressed	Display with ENTER Button Released	Remarks / Actions Required
OnAn	Oc 15.0	ONAN gradient in °C (gr, range 0-200 C)
Onanc	A 2.500	ONAN current in amps (Range 0.25 – 10.00 Amps)
onan H	H 1.0	Value per IEC354 (Range 1.0 to 1.4) See section 4.1
onan y	Y 1.6	Value per IEC354 (Range 1.5 to 2.2) See section 1.4
Ofan	Oc 16.0	OFAF Gradient in °C (gr, range 0-200 C)
Ofanc	A 3.750	OFAF current in amps (Range 0.25 - 10.00 Amps)
Ofan H	H 1.0	Value per IEC354 (Range 1.0 to 1.4) See section 1.4
ofan y	Y 1.6	Value per IEC354 (Range 1.5 to 2.2) See section 1.4
Ofaf	Oc 17.0	OFAF Gradient in °C (gr, range 0-200 C)
Ofafc	A 5.000	OFAF current in amps (Range 0.50 - 10.00 Amps)
Ofaf H	H 1.0	Value per IEC354 (Range 1.0 to 1.4) See section 1.4
ofaf y	Y 1.6	Value per IEC354 (Range 1.5 to 2.2) See section 1.4
Transf	T 480	Time in seconds, ONAN to OFAF & OFAF to ONAN

Table 6.6.2D

6.7.3 When the cool fail detection system is configured to use Current Transformer inputs the running FAN and PUMP currents are displayed at the end of the parameter setting process by means of using pass code 00101. The CT input range is translated to a displayed value of 0 - 99 by the combination of primary turns, CT type and external burden resistor.

When the PEAK TEMP button is pressed to save the changes, the Deviation and Delay figures are again offered and can be amended. For example if the fan running current was 60%, then setting a deviation of 20% would mean a cool fail alarm would occur if the running current were less than 40% or greater than 80% of that measured during the operational parameter setting process.

6.7.4 Reserved for calibration information if to be included.

6.7.5 Reserved for calibration information if to be included

**6.8 Returning to Default Settings**

6.8.1 A facility exists to return the 852 to its factory default operational settings. This function does not affect any calibration data that was entered at the factory.

6.8.2 To pass code to return the unit to default operational settings is 3381. To carry out the reset to defaults, proceed as shown below

Stage	Action & Response
1	Press and hold the SHIFT and ENTER buttons together until "rEAdy " is displayed. (The display will briefly show "Setup")
2	Release the SHIFT and ENTER buttons and the display shows "br1te" Al soltar los botones en el visor se leerá "brlte"
3	Press the ENTER button and the pass code prompt "----0" will be displayed with the zero digit flashing. Use the UP and LEFT buttons to enter a value of " 1". If you go beyond "1" the use SHIFT and UP buttons together to decrement it again.
4	When satisfied that the least significant digit is correct, press the LEFT button. The display will now change to this " ----0- " with the zero again flashing. The digit " 1" you have already programmed is now hidden, but it is remembered by the 852.
5	Use the UP button to set the value of the digit to " 8 " Again the SHIFT and UP buttons may be used to decrement the value if you overshoot.
6	Repeat the process 3381 has been entered and then press the ENTER button.
7	The display will briefly show " deflTs " and then return to displaying temperature.

**6.9 Relay Test Mode**

6.9.1 A special mode exists to verify that the operation of the 852 programmable relays occurs at the set points selected. A simulated temperature ramp is generated and displayed and it can be verified that relay operation occurs at the selected temperatures.

6.9.2 The relay test mode has a limitation that prevents the relays from operating if a PT100 fault is detected by the 852. In this instance the Pump relay is energised and the Fan, Alarm and Trip relays inhibited.

6.9.3 The ramp starts at 0°C and ramps up to 200°C and then returns down to 0°C after which the 852 reverts to the normal mode of operation.

- 6.9.4 The ramp rate is normally 1°C per second but this can be accelerated to 4°C per second as follows:  
 When ramping UP press and hold the UP button  
 When ramping DOWN press and hold both the SHIFT and UP buttons
- 6.9.5 The ramping can be temporarily stopped in either direction by pressing and holding the ENTER button.
- 6.9.6 The pass code to initiate the ramp cycle is 01508. To start the ramp cycle proceed as follows

<b>Stage</b>	<b>Action &amp; Response</b>
1	Press and hold the SHIFT and ENTER buttons together until "rEAdy " is displayed. (The display will briefly show "Setup" )
2	Release the SHIFT and ENTER buttons and the display shows "br1te"
3	Press the ENTER button and the pass code prompt "----0" will be displayed with the zero digit flashing. Use the UP and TOP OIL buttons to enter a value of " 8". If you go beyond "8" the use SHIFT and UP buttons together to decrement it again.
4	When satisfied that the least significant digit is correct, press the LEFT button. The display will now change to this " ---0- " with the zero again flashing. The digit " 8" you have already programmed is now hidden, but it is remembered by the 852.
5	Since the value is already at zero for the second digit use the LEFT button again to move on to the third digit. Use the UP button to set the value of the digit to " 5 " Again the SHIFT and UP buttons may be used to decrement the value if you overshoot.
6	Repeat the process 1508 has been entered and then press the ENTER button.
7	The display will briefly show the temperature updated once per second during the ramp cycle and then return to displaying the measured temperature.

## 6.10 Summary of Pass Codes

6.10.1 A Summary of Pass Codes used in the 852 is tabulated below

Code	Purpose
00042	Adjust Relay Operation Set points
00066	Adjust Operational Parameters
00067	Winding #1 parameters
00068	Winding #2 parameters
00077	Adjust MODBUS parameters
00141	Auto Cool mode
00101	Pumps and Fans CT Input Training Mode
01508	Relay Test Mode
01712	Relay operating mode selection (select HotSpot or Top Oil for each relay) (seek advice from Ashridge before use)
03381	Return Unit to default settings (excludes factory calibration)
00033	Select Normally energised or non-energised for Fan & Pump relays (seek advice from Ashridge before use)
*****	Factory Calibration Mode (password not disclosed)

## 7 MODBUS Networking

### 7.1 Introduction

7.1.1 The 852 Plus offers a flexible MODBUS Networking Interface using RS485 Data transmission. RTU modes of operation are supported.

7.1.2 The MODBUS Interface allows both reading of measurements and the overriding control of relays. This latter feature must be used with caution, as overridden relay will remain in that state until the programmable MODBUS timeout occurs or the unit is power cycled.

**7.2 Programming for MODBUS operation**

7.2.1 To configure the MODBUS Interface proceed as described in tables 7.2.1A and 7.2.1B below. The MODBUS configuration pass code is 00077

Stage	Action & Response
1	Press and hold the SHIFT and ENTER buttons together until "rEAdy " is displayed. (The display will briefly show "Setup" )
2	Release the SHIFT and ENTER buttons and the display shows "br1te"
3	Press the ENTER button and the pass code prompt "----0" will be displayed with the zero digit flashing. Use the UP and LEFT buttons to enter a value of " 7"". If you go beyond "7" the use SHIFT and UP buttons together to decrement it again.
4	When satisfied that the least significant digit is correct, press the LEFT button. The display will now change to this " ---0- " with the zero again flashing. The digit " 7" you have already programmed is now hidden, but it is remembered by the 852.
5	Use the UP button to set the value of the digit to " 7 " Again the SHIFT and UP buttons may be used to decrement the value if you overshoot.
6	Now press and hold the ENTER button. The display will show "neT-7-". Now release the button and the display will now show "adr 1 " with the right hand " 1 " flashing
7	Using the CT and SHIFT buttons, increment or decrement the digit to the desired address low order address value. Note that the increment and decrement of a digit will overflow and underflow to the higher order digits.
8	Use LEFT to move on to the next digit. The LEFT and SHIFT buttons pressed together will return to the previous digit.
9	When satisfied press and hold the ENTER button to show the next parameter. The entire sequence may now be repeated for each parameter setting value as shown in Table 6.6.2B below.

Table 7.2.1A

Display with ENTER Button Pressed	Display with ENTER Button Released	Remarks / Actions Required
neT-7-	Adr 1	<b>MODBUS Network Address select from range of 1 to 99 inclusive.</b>
NeT	RTu	<b>MODBUS RTU mode of Operation only</b>
Baud	(4.8 9.6 57.6)	<b>Select the Network Baud rate from three options 4800bps, 9600bps or 57,600bps</b>
coll8	Dy 30	<b>Select the MODBUS timeout period. Range 1-180 Minutes.</b>

Table 7.2.1B

- 7.2.2 When satisfied with the value of all parameters then either:
- (a) Press PEAK TEMP to save the changes. " sAUE " is displayed.
  - (b) Press SHIFT an PEAK TEMP to abort the changes " AborT" is displayed.

### 7.3 MODBUS Networking Overview

7.3.1 The 852 has four user accessible registers which are:

- 01: Coil Status
- 02: Input Status
- 03: Holding Register
- 04: Input Register

In the examples that follow, we will illustrate access to each register and the values held in each field using the MODSCAN32 programme. A fully functional 30-day evaluation version of this programme is available from the developer at <http://www.win-tech.com/html/modscan32.htm>

7.3.2 The MODSCAN32 programme is simple to set-up on any IBM compatible PC with RS485 connectivity and an example set-up screen is shown below. Please note that screen shots in this manual may not reflect the latest version of the software.

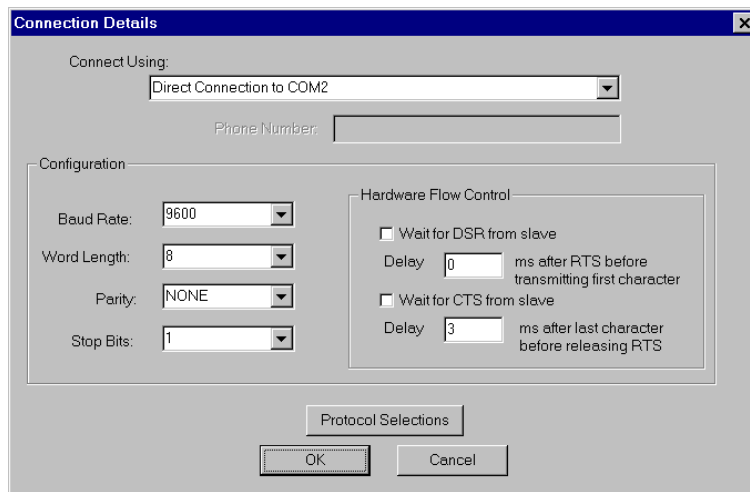

### 7.4 MODBUS Coil Status

7.4.1 The status of five of the output relays (not the watchdog) can be accessed and modified through the coil status register. The ability to remotely override relay states must be used with caution, as an overridden relay will remain in the remotely set state until the programmable MODBUS timeout occurs or the unit is power cycled.

7.4.2 The MODSCAN32 screenshot below shows the five accessible coils. Logic <0> represents an OFF state. Table 7.4 defines the address of each coil.

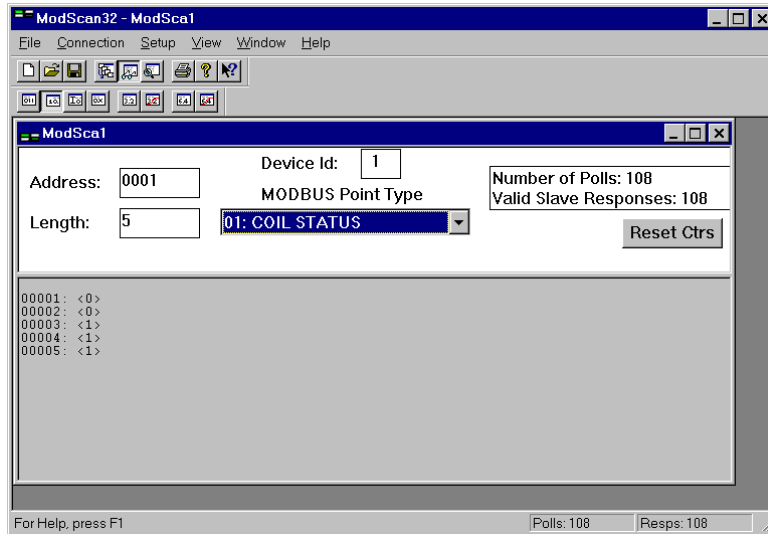

Address	Relay
00001	Alarm Relay
00002	Trip Relay
00003	Pump Relay
00004	Fan Relay
00005	Cool Fail Relay

Table 7.4

## 7.5 MODBUS Input Status

7.5.1 The status of the four digital inputs can be accessed through the Input Status register. When the digital inputs are being used as CT current inputs the value returned is <0>.

7.5.2 The MODSCAN32 screenshot below shows the four digital inputs. Logic <0> represents an OFF state. Table 7.5 defines the address of each coil

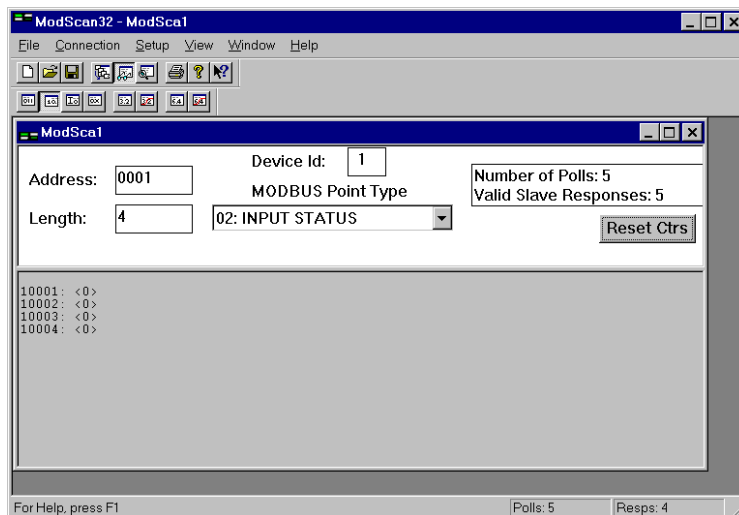

Figure 7.5

Address	Input
10001	Pump Input
10002	Fan Input
10003	EN Input (remote cooling start input)
10004	FN2 Input (not used)

Table 7.5

## 7.6 MODBUS Holding Register

7.6.1 To allow access to the register set a correct value of pass code must first be entered into address 40001. The pass code is 00273. Five minutes is allowed for pass code entry before timing out. During this time the trip relay is inhibited. It is possible to exit during the five-minute period by entering an incorrect pass code.

7.6.2 The MODSCAN32 screen shot below shows some of the 18 Analogue values maintained in the Holding Register and Table 7.6 below details of each entry.

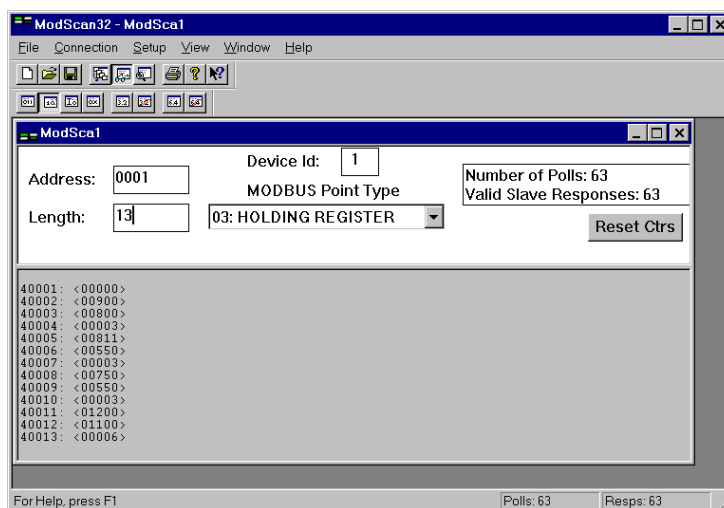

Figure 7.6

Address	Parameter	Value
40001	Pass Code = 00273	00273
40002	Alarm ON Temperature °C x 10 e.g. 90.0°C	00900
40003	Alarm OFF Temperature °C x 10 e.g. 80.0°C	00800
40004	Alarm Debounce Time (Seconds) e.g. 3	00003
40005	Pump ON Temperature °C x 10 e.g. 81.1°C	00811
40006	Pump OFF Temperature °C x 10 e.g. 55.0°C	00550
40007	Pump Debounce Time (Seconds) e.g. 3	00003
40008	Fan ON Temperature °C x 10 e.g. 75.0°C	00750
40009	Fan OFF Temperature °C x 10 e.g. 55.0°C	00550
40010	Fan Debounce Time (Seconds) e.g. 3	00003
40011	Trip ON Temperature °C x 10 e.g. 120.0°C	01200
40012	Trip OFF Temperature °C x 10 e.g. 110.0°C	01100
40013	Trip Debounce Time (Seconds) eg 6	00006
40014	Alarm ON Temperature °C x 10 e.g. 90.0°C	00900
40015	Alarm OFF Temperature °C x 10 e.g. 80.0°C	00800
40016	Alarm Debounce Time (Seconds) e.g. 3	00003
40017	Reserved	
40018	Reserved	
40019	Reserved	
40020	Relay 6 ON Temperature °C x 10 e.g. 75.0°C	00750
40021	Relay 6 OFF Temperature °C x 10 e.g. 55.0°C	00550
40022	Relay 6 Debounce Time (Seconds) eg 6	00006
40026	Winding Temperature # 1 °C x 10 e.g. 110.0°C	01100
40027	Winding Temperature # 2 °C x 10 e.g. 110.0°C	01100

Table 7.4

## 7.7 MODBUS Input Register

7.7.1 The Input Register allows read only access to the real time clock, stored and displayed values and some other parameters.

7.7.2 The MODSCAN32 screen shot below shows the twelve accessible values and table 7.7 shows the address of each of the parameters.

Figure 7.7

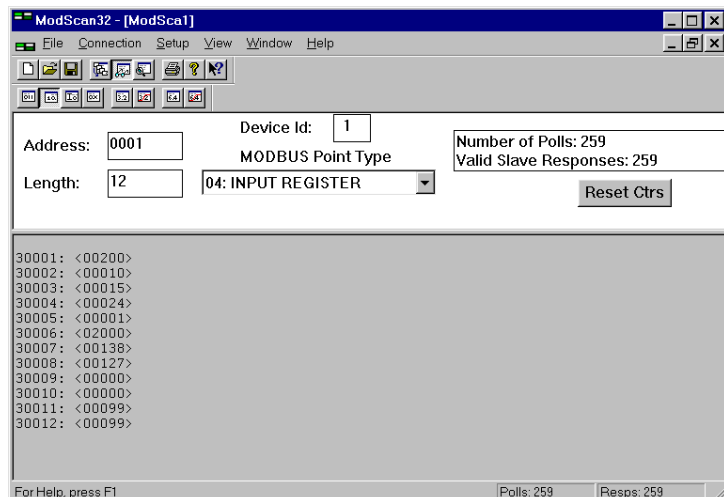

Address	Parameter	Value
30001	Peak Temperature °C e.g. 200 °C	00200
30002	Real Time Clock Hours e.g. 10 Hours	00010
30003	Real Time Clock Minutes e.g. 15 Minutes	00015
30004	Real Time Clock Day e.g. 24 <sup>th</sup>	00024
30005	Real Time Clock Month e.g. January	00001
30006	Real Time Clock Year e.g. 2002	02002
30007	Current Displayed Temperature °C e.g. 138°C	00138
30008	Current Top Oil Temperature °C e.g. 127°C	00127
30009	Pump CT Value (0-99)	00099
30010	Fan1 CT Value (0-99)	00099
30011	EN Value (0-99)	00099
30012	FN2 Value Range 0 - 99 = 0 to 2.2VAC e.g. 2.2VAC	00099

Table 7.7

## **8 Daily Operation**

### **8.1 Monitoring Input Values**

- 8.1.1 In normal operation, the 852 5-digit display shows the temperature measured by the PT100 sensor, corrected by the value of current flowing in the circuit attached to the transformer in accordance with IEC354.
- 8.1.2 The Top Oil temperature is continuously displayed on the lower 3 digit display.
- 8.1.3 The Current Transformer input from the transformer circuit can be displayed by pressing the SELECT button, which toggles through each of the Winding temperatures before toggling through the Current for each winding. The display will revert to displaying the hottest Winding temperature after 1 minute with no button activity.
- 8.1.4 The peak temperature reached by the oil can be displayed along with the time and date of that peak. To display the peak temperature, press and hold the PEAK TEMP button. When the PEAK TEMP button is released the time and date of the peak temperature event will be displayed for approximately two seconds each.
- 8.1.5 To reset the peak temperature value press the SHIFT and PEAK TEMP buttons and the display will show " PH res " and the value reset to the corrected value currently being measured.

8.1.6 When connected to the 852, the Pump and Fan Running Currents can be displayed at any time by pressing the SHIFT and UP buttons together. A display will appear with two digits at the left and right hand sides " 24 42 ". The two left most digits represent the pump running current and the two digits at the right the FAN running current.

These figures are not amperes, but are a factor based on the value of current in the CT. The displayed range for each pair of digits is 0 to 99.

## 8.2 Error and Alarm Displays

8.2.1 The 852 displays a number of Error Messages during operation as tabulated below.

Message	Meaning / Action Required
PT100 Fault	The PT100 Sensor and/or associated wiring has gone open or short circuit.
Ipfall	The Isolated Input Circuitry of the Unit has failed.
SeTErr	Press the UP Button to reset to Factory default
CalErr	Press the UP Button to reset to Factory default
PH err	Press the UP Button to reset to Factory default

## 9 Application Notes

### 9.1 Application Note No 1: Using external Current Transformers to monitor the Fan and Pump running currents and control the Cool Fail function

#### 9.1.1 Introduction

The winding or Hot Spot differential temperature is calculated by the 852 using a combination of the CT input, the Fan (Fn) & Pump (Pp) Digital inputs and the remote Fan & Pump operation digital input (SP). It is therefore imperative that the following methods to achieve this are fully understood before commissioning.

**9.1.2 Setting Up**

9.1.2.1 Under settings password (66) ensure that **'type' is set to 'CT' i.e.:**

Op4 S	ct t-oil b-oil Amb	Selects if output 4 provides top oil, bottom oil, Ambient temperature or the Current Transformer input value
Type	CoTacT cT None	<b>Select the type of cool fail input detection between contact or CT input Plus or minus % of input deviation for Current Transformer type cool fail inputs. Range 0-100</b>
DeV	10	Plus or minus % of input deviation for Current Transformer type cool fail inputs. Range 0-100

9.1.2.2 Initially select Burden resistor Rx and CT turns ration from the table below or contact Ashridge Sales office for details of other values that may be required.

9.1.2.3 Ensure that wiring is complete, working correctly and that all site safety procedures have been followed before continuing.

9.1.2.4 Enter password 101 and switch on the Fans and Pumps. Their respective running currents are now displayed as values of 0-99 (Pump on the left and Fan on the right). For normal applications the running currents should display values between 40-80, the actual currents will depend on the CT turns ratio and burden resistor combination, where the running currents are outside these figures it may not be possible for the 'Cool-Fail' function to operate normally. It may be necessary to change the burden resistor or the CT primary turns ratio in order to meet the above requirements.

9.1.2.5 When the running currents are within the parameters noted above press the SAVE (PEAK TEMP) button (this has now saved the normal running current to memory) otherwise abort by holding down the SHIFT button and pressing the PEAK TEMP button.

9.1.2.6 The next parameter is 'deU F' (Fan deviation), the percentage deviation from the saved running current that will cause a 'Cool-Fail' alarm and must be decided by site conditions such as the effects of high winds etc on the Fan running current. When the correct figure has been entered press the PEAK TEMP button.

9.1.2.7 The next parameter is 'deU P' (Pump deviation), the percentage deviation from the saved running current that will cause a 'Cool-Fail' alarm and must be decided by site conditions. When the correct figure has been entered press the PEAK TEMP button.

9.1.2.8 The final parameter is the time delay for the 'Cool-Fail' alarm to be indicated after detection of a deviation and is displayed in minutes, enter time required and press the PEAK TEMP button.

Note 1:

When used in CT digital input mode the 2 off CT running currents may be monitored at any time by pressing and holding down the 'SHIFT' and 'UP' buttons.

Note 2:

When used in this mode and the Pump fails to operate with the Fans operating normally, the Cool-Fail message be displayed, the relay will operate and the 'Hot Spot' gradient will remain in the ONAN state.

Where the Fan fails to work but the Pump operates normally, the Cool-Fail message will be displayed, the relay will operate and the 'Hot Spot' gradient will continue to operate correctly to OFAF

Note 3:

Where the forced cooling consists of only fans or pumps (but not both!) connect the two digital inputs (Fn & Pp) together using a wire link.

### **9.1.3 Wiring Information**

9.1.3.1 The wiring arrangements for various Fan & Pump CT Type Inputs are shown in Figures 9.1.3A & 9.1.3B below.

9.1.3.2 Figure 9.1.3A shows the 852 wiring arrangement for CT type input where the transformer is fitted with both Fan and Pump. With this arrangement when commissioning and verifying the 'load' CT input it is important to ensure that the correct digital inputs are made as these determine the appropriate cooling gradient. For instance if a full 5A (OFAF) input is applied and the digital inputs are left in the Natural cooling state the 852 will remain on the ONAN gradient resulting in a much higher temperature than expected

9.1.3.3 Figure 9.1.3B (left) shows the 852 wiring arrangement for CT type input where the transformer is fitted with a Pump only. With this arrangement ensure that the FAN and Pump ON and OFF settings are identical.

9.1.3.4 Figure 9.1.3B (right) shows the 852 wiring arrangement for CT type input where the transformer is fitted with a Fan only. With this arrangement ensure that the FAN and Pump ON and OFF settings are identical.

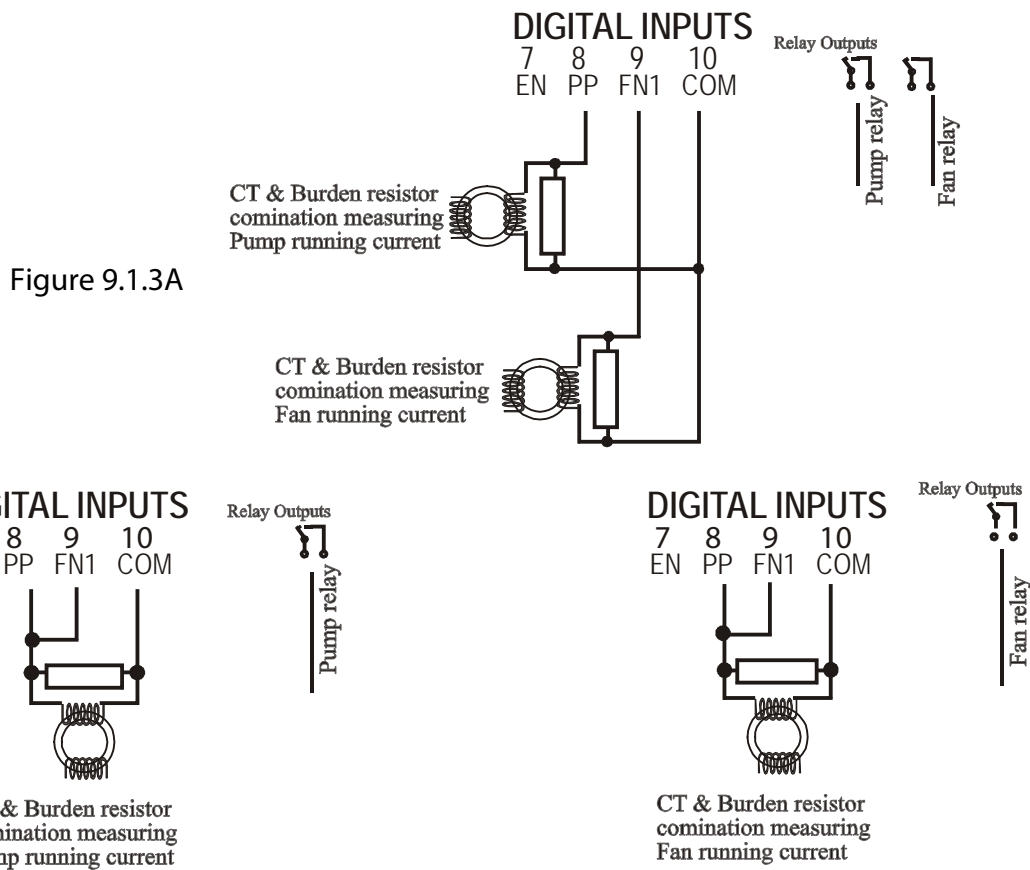

Figure 9.1.3A

Figure 9.1.3B

#### 9.1.4 Guidance notes regarding Wedding Ring CT, Burden Resistors and Voltage Inputs

9.1.4.1 The 852 monitors fan and pump running currents by feeding voltage signals into the fan and pump digital inputs. (Although described as "digital inputs" these do, in fact accept three types of input, i.e. (i) simple 0 or 1 digital input (ii) dc analogue input. The voltages are derived from externally mounted wedding ring Current Transformers supplying external burden resistors.

9.1.4.2 Number of wedding ring CT primary turns and burden resistor values are derived from table 9.1.4 below.

9.1.4.3 The values listed below assume the use of a 10/0.005 (0.01VA) CT (OD=25, ID=12mm) and are given as guidance only.

9.1.4.4 During commissioning it may become apparent that the turn's ration/burden resistor values may be incorrect and that some 'site tuning' may be required.

Pump or Total Fan Current Range (A)	Reading	Number of Primary Turns	Burden Resistor (Ω)
1.00 – 2.00	35 - 70	5	150
2.00 – 4.00	37 – 75	4	100
3.00 – 5.00	41 – 69	3	100
5.00 – 8.00	46 – 74	2	100
7.00 – 10.00	48 – 70	1	150
10.00-16.00	47 - 74	1	100
12.00-21.00	46 - 80	1	82

Table 9.1.4

9.2 **Application Note No 2:**

**Using a clean contact closure from Fans and Pump contactor to control Cool Fail function.**

**9.2.1 Introduction**

9.2.1.1 The winding or Hot Spot differential temperature is calculated by the 852 using a combination of the CT input, the Fan (Fn) & Pump (Pp) Digital (inputs and the remote Fan & Pump operation digital input (SP). It is therefore imperative that the following methods to achieve this are fully understood before commissioning.

9.2.1.2 Using settings password (66) ensure the type is set to contact closure and that the PCB links are set accordingly.

op2	4-20 0-10 0-20	Select output current range using the CT button
Type	CoTacT cT None	Select the type of cool fail input detection between contact or CT input (Plus or minus % of input deviation for CT type input)

**9.2.3 Wiring Information**

9.2.3.1 The wiring arrangements for various Fan & Pump CT Type Inputs are shown in Figures 9.2.3A & 9.2.3B below.

9.2.3.2 Figure 9.2.3A shows the 852 wiring arrangement for contact type input where both Fan and Pump are used.

9.2.3.3 Figure 9.2.3B (left) shows the 852 wiring arrangement for contact type input where the transformer is fitted with a Pump only.

9.2.3.4 Figure 9.2.3B (right) shows the 852 wiring arrangement for contact type input where the transformer is fitted with a Fan only.

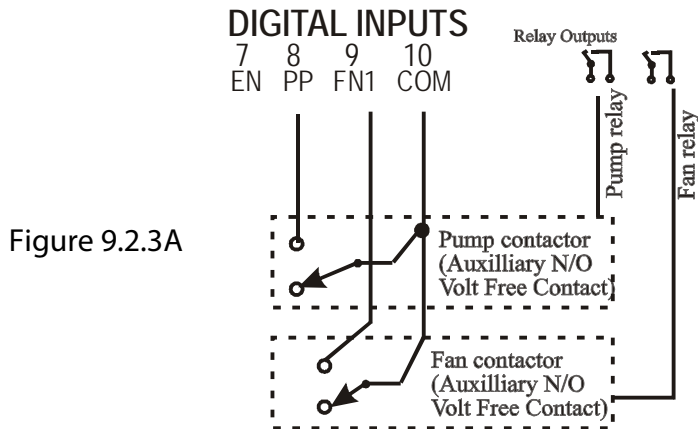

Figure 9.2.3A

For Pump Only

For Fan Only

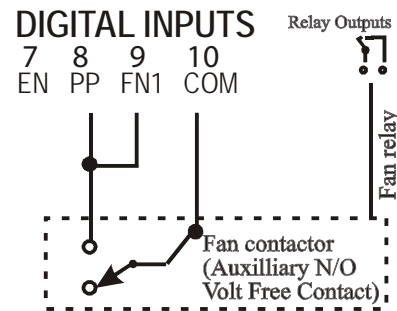
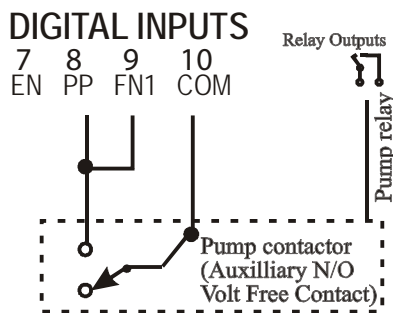

Figure 9.2.3B

**9.2.4 Additional Notes**

Note 1:

When used in this mode and the Pump fails to operate with the fans operating normally, the Cool-Fail message and relay will operate, however the 'Hot Spot' gradient will remain in the ONAN state. Where the Fan fails to work but the Pump operates normally, the Cool-Fail message and the relay will operate and the 'Hot Spot' gradient will continue to operate correctly.

Note 2:

Where the forced cooling consists of only fans or pumps (but not both!) connect the two digital inputs (Fn & Pp) together using a wire link.

Note 3:

Main CT Calibration check: It is important to note that it is not possible to check the calibration of the main CT until the Cool Fail system has been calibrated as the 852 will not switch from the ONAN to the OFAF gradient until the Pump is 'seen' to be working correctly.

For example: Where a CT input of 5 Amps has been input and the 852 has not initiated the Fans and Pumps the 'Hot Spot' reading will remain on the ONAN gradient and the 'Hot Spot' reading will appear too.

**9.3 Application Note No 3: Step Change Mode Programming.**

**9.3.1 Introduction and setting procedure**

The Step Change mode is used where a high initial CT current could cause the core to overheat before the temperature rises sufficiently to switch on the Pump at the normal pre-set temperature. (See manual pages 2 & 5)

9.3.2 Using the settings password (66) ensure that the “ On-sT” is set to the “sT” option as shown in the table below:

T-lag	N1n 8	Exponential timer to simulate thermal lag in transformer. Range 0 – 10 Minutes in 1 minute steps
on-sT	onan STep	Enables Step Mode operation of cooling pump
thresH	A 2500	This only appears if “ on-sT” is set to STEP. This sets the CT current threshold for the step change (after the CT current has been higher than the threshold for more than 90 seconds range 1 - 240)
TIMe	Min 90	This only appears if “ on-sT” is set to STEP. Time before the Pump returns to local control. Range 1 – 240 Minutes

The “ ThresH” parameter is the CT current required to initiate this function (The CT input must remain above this point for 90 seconds before the function becomes active).

The “ TIMe” parameter sets the time period, in minutes for the pump to remain energised after the CT current has returned to normal levels.

Notes

Step Change mode uses the 'LOAD' or CT input to override the normal method of starting the Cooling system and start the circulating pump for a predetermined period.

In this mode the CT current must remain above a threshold value (as set by the user) for 90 seconds before the function becomes active. Once initiated the Pump will remain energised for the time period (set by the user) before returning to normal 'Hot Spot' temperature controlled operation.

For instance: After this time period expires and the transformer temperature is below the Pump 'Off' value and the CT current is below the threshold value the pump relay will de-energise.

## 10 Appendices

### 10.1 Commissioning

10.1.1 The 852 commissioning procedure comprises two steps. Firstly, checking the cool fail gradient and CT inputs. Then secondly checking the relay operation.

10.1.2 To check the cooling gradients and CT inputs proceed as follows:

- a) Correctly set the ONAN and OFAF conditions under password 66 and save.
- b) Ensure steady Top Oil temperature, either using PT100 simulator or by hot bath technique with temperature below Fan and Pump switch ON point.
- c) Simulate a CT input for ONAN (Naturally Cooled) load, this should be confirmed by pressing the CT (Amps) button. The Hot-Spot temperature will now indicate the Top oil temperature plus the offset used for the ONAN setting.
- d) Note: Where the T-Lag has been used this will add an exponential timer and the Hot-Spot temperature will take up to 25 minutes to stabilise.
- e) Ensure steady Top Oil temperature, either using PT100 simulator or by hot bath technique with temperature above Fan and Pump switch ON point or manually switch on fans and pumps. At this point it is important to ensure that Digital inputs are working correctly (see Ashridge 852 Application Notes 1 & 2).
- f) Simulate a CT input for full load, this should be confirmed by pressing the CT (Amps) button. The Hot-Spot temperature will now indicate the Top oil temperature plus the offset used for the OFAF full load setting.

Note 1:

Where the T-Lag has been used this will add an exponential timer and the Hot-Spot temperature will take up to 25 minutes to stabilise.

Note 2:

The 852 will remain on the ONAN gradient until the digital inputs are operating correctly (see 852 Application Notes 1 & 2).

**10.1.3 To check the relay operation proceed as follows:**

- a) Enter password 1508
- b) When password 1508 is entered, the unit will de-energise all relays and return the display to 0 C the display will then slowly ramp up at approximately 1 C per second (pressing and holding the CT Button will increase this to 4 C per second). This allows the user to observe the relays switching on at their set values (to temporarily halt the rising temperature press and hold the ENTER button) This will be necessary as the relay timers remain operational.

Note:

When 'PT100 Fault' is enabled this inhibits the display from showing the rising/falling temperature and Pump relay remains energised, Fan, Alarm & Trip relays are also inhibited.

- c) When the temperature reaches 200 C the temperature will decrement at approximately 1 C per second (pressing and holding the CT and SHIFT buttons will increase the rate to 4 C per second). This allows the user to observe the relays switching off at their set values (to temporarily halt the falling temperature press and hold the ENTER button).

**10.2 852 Specifications**

**10.3 Auto Cool mode**

The Auto Cool parameters comprises the entries for:

- Enabled or disabled
- Alarm type
- Duration of cooling cycle
- Start time of cooling cycle
- Interval between cooling cycles

The pass code for Auto Cool is 00141. When ready to programme the operational parameters proceed as follows. Note that the figures shown in these procedures are those for an ex-factory 852. Subsequent field programming will cause them to be different

**Programming for Auto Cool operation**

Stage	Action & Response
1	Press and hold the SHIFT and ENTER buttons together until "rEAdy " is displayed. (The display will briefly show "Setup")
2	Release the SHIFT and ENTER buttons and the display shows "br1te"
3	Press the ENTER button and the pass code prompt "----0" will be displayed with the zero digit flashing. Use the UP and TOP OIL buttons to enter a value of " 1". If you go beyond "8" the use SHIFT and UP buttons together to decrement it again.
4	When satisfied that the least significant digit is correct, press the LEFT button. The display will now change to this " ----0- " with the zero again flashing. The digit " 4" you have already programmed is now hidden, but it is remembered by the 852.
5	Since the value is already at zero for the second digit use the LEFT button again to move on to the third digit. Use the UP button to set the value of the digit to " 1 " Again the SHIFT and UP buttons may be used to decrement the value if you overshoot.

Display with ENTER Button Pressed	Display with ENTER Button Released	Remarks / Actions Required
AutoC	OFF ON	Enables or Disables Auto Cool
Alarn	Type 1 Type 2 Type 3	Exponential timer to simulate thermal lag in transformer. Range 0 – 10 Minutes in 1 minute steps
Intvl	7	Days interval between cooling cycles (range 1-30 days)
Run	10	Cooling cycle Run Time in minutes (range 3-120 minutes)
Start	10 (lower display reads Hr)	Hour Start time in 24 hr clock mode
Start	0 (lower display reads nin)	Minutes start time

**Notes on Alarm types (Type 1, 2 or 3 (default 1):**

- a. Type 1 (Single stage cool fail alarm), i.e. Normal cool fail mode
- b. Type 2 (2 stage cool fail alarm for Fans only), i.e. Where 2 is selected the terms "DFI" and second line DF2" is added for the Fans (Pumps remains "deV" under password 101 (teach running currents) these select the alarm deviation and conditions for both the analogue output 2 (to energise external relay) and the normal cool fail relay. When this option has been selected the analogue output 2 automatically shows "rel 7" under password 66 to indicate that output 2 is no longer available as an analogue output.
- c. Type 3 (2 stage cool fail alarm for both Fans and Pumps), i.e. Where 3 is selected the terms "DFI " and "DF2" is added for Fans and "DPI " and "DP2" is added for Pumps under password 101 (teach running currents) these select the percentage deviation and conditions for both the analogue output 2 (to energise external relay) and the standard cool fail relay. When this option has been selected the analogue output 2 automatically shows "rel 7" under password 66 to indicate that output 2 is no longer available as an analogue output

**Notes on Auto Cool mode**

- d. When Auto Cool has been enabled the unit will operate at the first available time following initiation, followed thereafter at the interval days set.
- e. The unit will restart the timing process if there has been an interruption in the power supply or after any of the settings have been changed and saved.
- f. Under password 66 the 2nd analogue output will show the new term "rel 7" when condition 2 or 3 has been selected under password 141, see above. For types 1 and 2 the external relay shown below will be required, this is a high sensitivity DIN rail mounted relay with c/o contacts rated at 120vdc 300mA breaking (see specification sheet for full details)

**USER NOTES:**

**11 Record sheet**

Series 852-216 Record Sheet, Firmware version:.....Job No:.....SN.....

User setting	Details
	User password (42)
	<b>Alarm ON</b> (Default 90.0°C rising)
	<b>Alarm OFF</b> (Default 85.0°C falling)
	<b>Alarm relay de-bounce time</b> (Default 3 seconds, max 60 secs)
	<b>Pump ON</b> (Default 75.0°C rising)
	<b>Pump OFF</b> (Default 55.0°C falling)
	<b>Pump relay de-bounce time</b> (Default 3 seconds, max 60 secs)
	<b>Fans1 ON</b> (Default 75.0°C rising)
	<b>Fans1 OFF</b> (Default 55.0°C falling)
	<b>Fans1 relay de-bounce time</b> (Default 3 seconds, max 60 secs)
	<b>Trip ON</b> (Default 120.0°C rising)
	<b>Trip OFF</b> (Default 115.0°C falling)
	<b>Trip relay de-bounce time</b> (Default 6 seconds, max 60 secs)
	<b>Rel 6 ON</b> (Default 75.0°C rising)
	<b>Rel 6 OFF</b> (Default 55.0°C falling)
	<b>Rel 6 relay de-bounce time</b> (Default 3 seconds, max 60 secs)
	User password (66)
	Grad User enters number of gradients required (Default 1)
	<b>Thermal lag time</b> (Default 8 minutes)
	Rolling Average (default 2)
	<b>O/p 1 n</b> (Use up key to toggle between 4-20, 0-10, 0-20mA, Default 4-20mA)
	<b>Range</b> (0-200, 0-150, 30-150 degrees C, Default = 0-200)
	<b>O/p 2 n</b> (Use up key to toggle between 4-20, 0-10, 0-20mA, Default 4-20mA)
	<b>O/p 2 S</b> (Use up key to toggle between t/oil, ct or HS2 (Winding 2 Hotspot temperature) (Default t/oil)
	Type; Toggles Contact, ct or none (Default contact)
	<b>Deviation</b> (when in ct mode, Default 10)
	Delay before cool fail message (Default 2 minutes)

**Single gradients shown.**

	User password 67 (Winding #1)
	<b>ONAN</b> (Thermal image offset in °C, range 0-200, Default 15°C)
	<b>CT amps</b> (For the ONAN offset in amps, Default 2.500 Amps)
	<b>ONAN 'H'</b> (Default 1.0)
	<b>ONAN 'y'</b> (Default 1.6)
	User password 68 (Winding #2)
	<b>ONAN</b> (Thermal image offset in °C, range 0-200, Default 15°C)
	<b>CT amps</b> (For the ONAN offset in amps, Default 2.500 Amps)
	<b>ONAN 'H'</b> (Default 1.0)
	<b>ONAN 'y'</b> (Default 1.6)

**Calibration and Final Inspection details** (Tick boxes and make notes as appropriate)

PT100 calibration (s)	<input type="checkbox"/>	Bump test	<input type="checkbox"/>
CT calibration (s)	<input type="checkbox"/>	Conformal coating	<input type="checkbox"/>
O/P calibration (s)	<input type="checkbox"/>	100 hour (minimum) soak test	<input type="checkbox"/>
Embedded Serial number	<input type="checkbox"/>	Labels attached & settings checked	<input type="checkbox"/>
Relays tested	<input type="checkbox"/>	Check Cool Fail timer (2 mins)	<input type="checkbox"/>
24Vdc and analogue outputs	<input type="checkbox"/>	Final inspection	<input type="checkbox"/>
Time & Date set	<input type="checkbox"/>	Signature & date	<input type="checkbox"/>